

REV.	DATE	ECO	DESCRIPTION	REV'D	CHK'D
1.0	28/10/2023	-	INITIAL RELEASE	AN	MS
2.0	31/07/2023	-	ADDED HVDC DETAILS	SR	HS

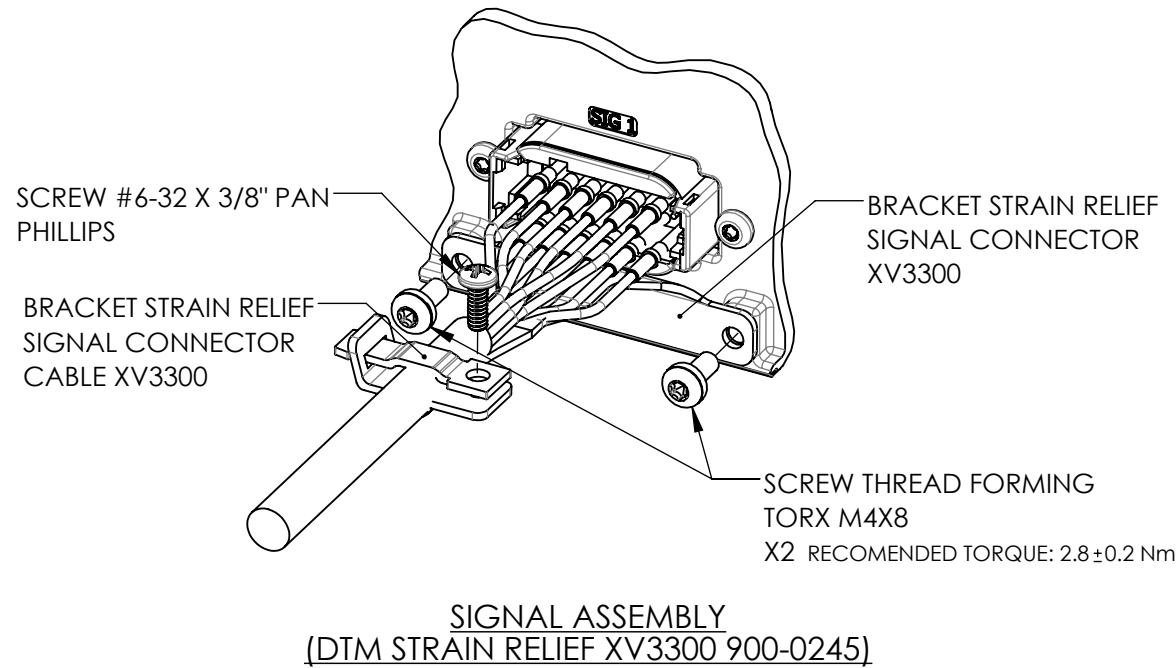
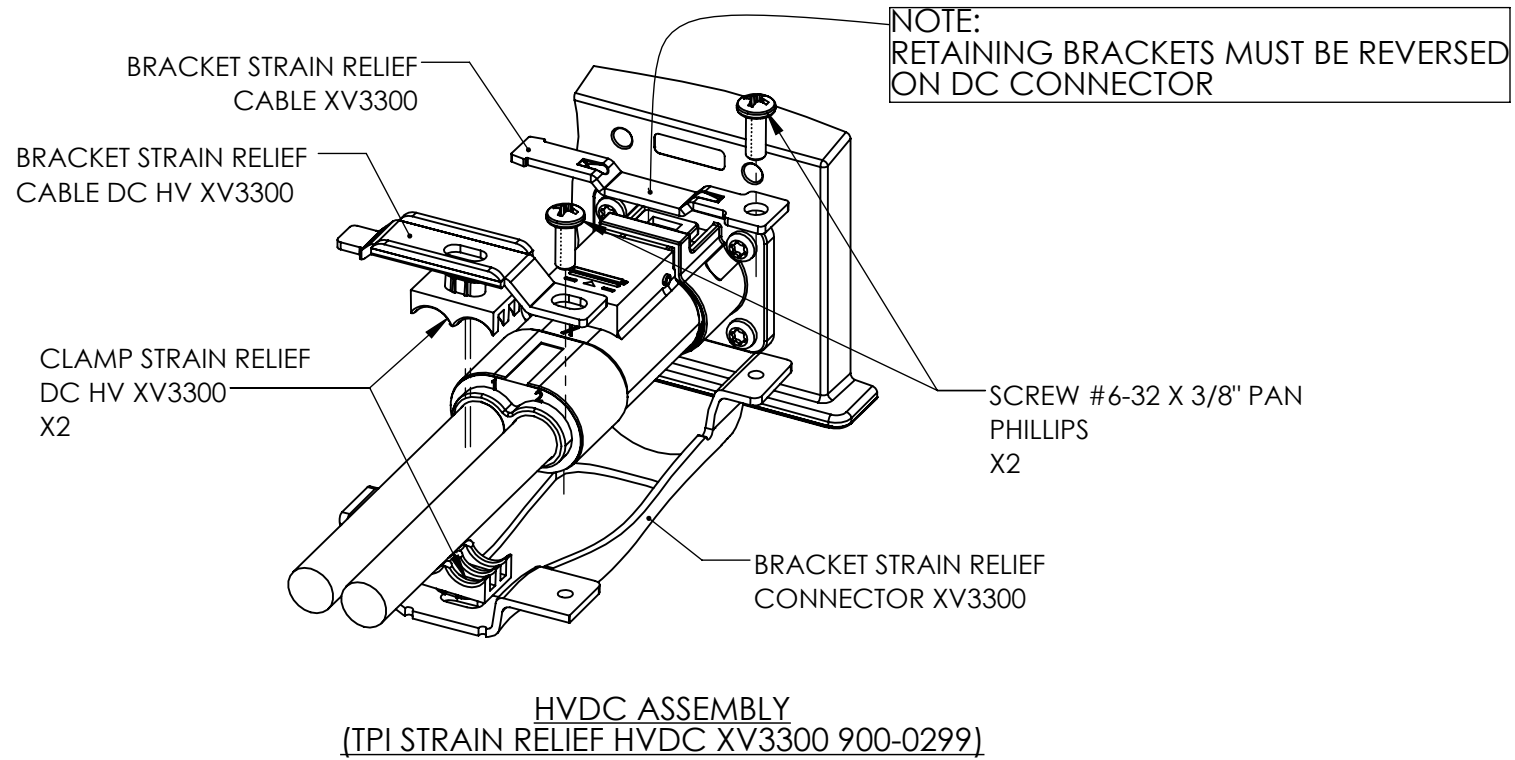
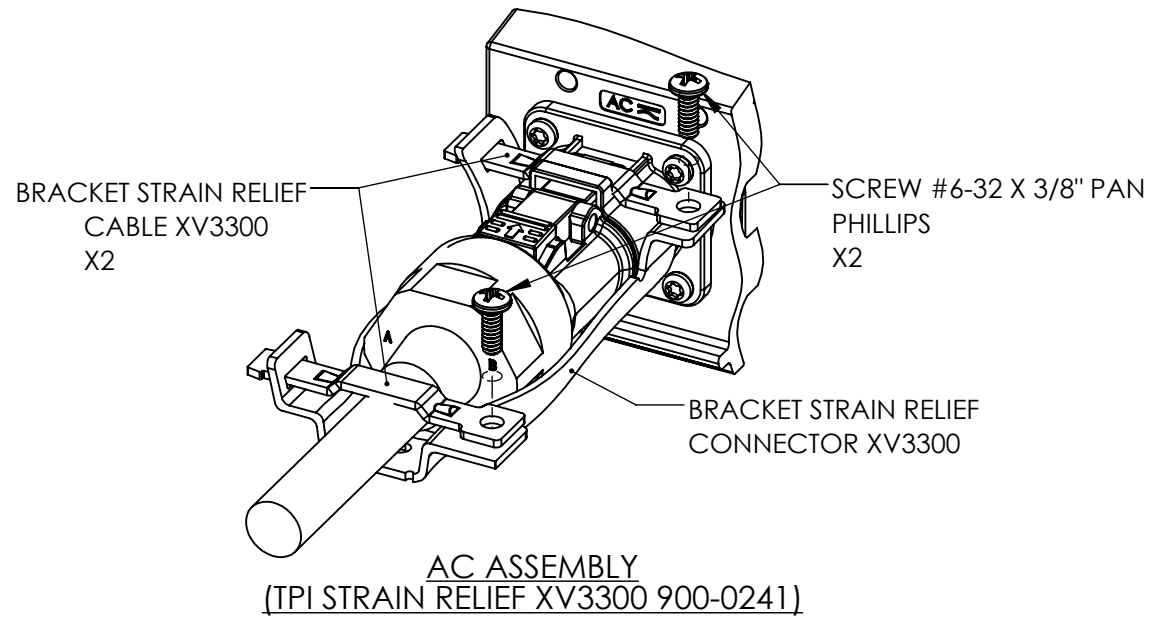
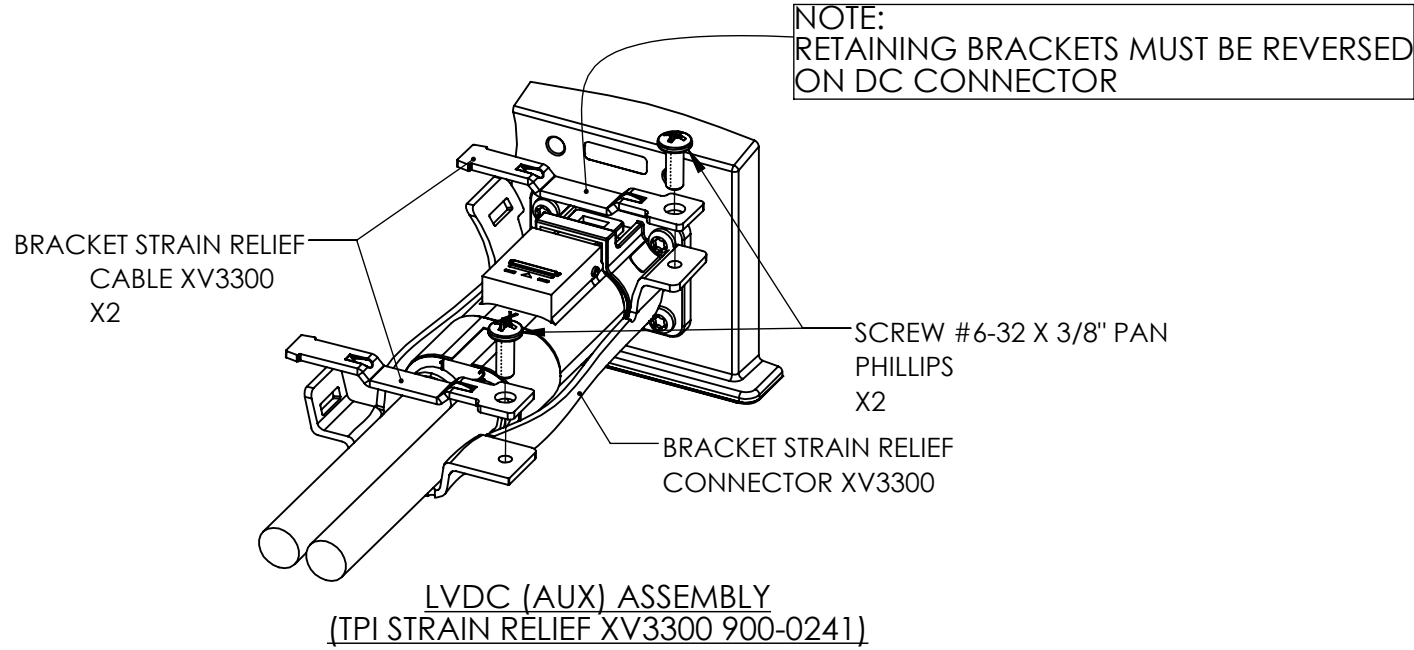

- NOTES:
- INSTALL CHARGER END FIRST.
 - RECOMENDED TORQUE: 2.0 ± 0.2 Nm. UNLESS OTHERWISE SPECIFIED. DO NOT OVERTIGHTEN.

CONFIDENTIAL INFORMATION OF DELTA-Q TECHNOLOGIES INC.
 © COPYRIGHT 2022 DELTA-Q TECHNOLOGIES INC. ALL RIGHTS RESERVED. ALL TRADEMARKS ARE OWNED BY DELTA-Q TECHNOLOGIES INC. AND SHALL NOT BE USED OR REPRODUCED IN ANY FORM OR FOR ANY PURPOSE WHATSOEVER, WITHOUT THE EXPRESS WRITTEN PERMISSION OF DELTA-Q TECHNOLOGIES INC.

DRAWING PER: ASME Y14.5-2009	
TOLERANCE FOR ALL SURFACES UNLESS OTHERWISE SPECIFIED:	
TOLERANCES: (UNLESS OTHERWISE SPECIFIED)	ANGLES $\pm 0.5^\circ$
	X ± 0.5
	X.X ± 0.3
	X.XX ± 0.15
	BENDS 0.5R
APPROVED: SEE ARENA	
DRAWN: AN	28/10/2022
DESIGNED: MS	08/11/2022
DIMENSIONS ARE IN MILLIMETERS DO NOT SCALE	

FINISH	
MATERIAL	
MASS (KG)	

PART NUMBER: **710-0274**

INSTALLATION GUIDE
STRAIN RELIEF BRACKETS
XV3300

APPROVED: SEE ARENA
 DRAWN: AN
 DESIGNED: MS

SIZE: **B** DOCUMENT NUMBER: **710-0274 R 2.0 _DRW**

SCALE: NTS SHEET 1 OF 1